

DESCRIPTION

- Welded steel frame.
- Coated steel actuator.
- RAL 9016 white paint (standard color).
- Other color on request.

MAIN FEATURES

- 45 t load capacity actuator, with three pistons and a screw extension.
- Needle manometer.
- Quick air inlet (oleopneumatic pump supply).
- Air inlet pressure control valve.
- Wheel with parking brakes.
- Fluid level indicator.
- Operator safety device.

STRENGTHS

- Carrying handle.
- Pump extension.
- Towable up to 5 km/h.
- Skydrol resistant paint.
- Unpainted parts corrosion treated.
- "Made in France" quality.
- Operation and maintenance manual (French and English).
- Three years warranty (except paint and wear parts).

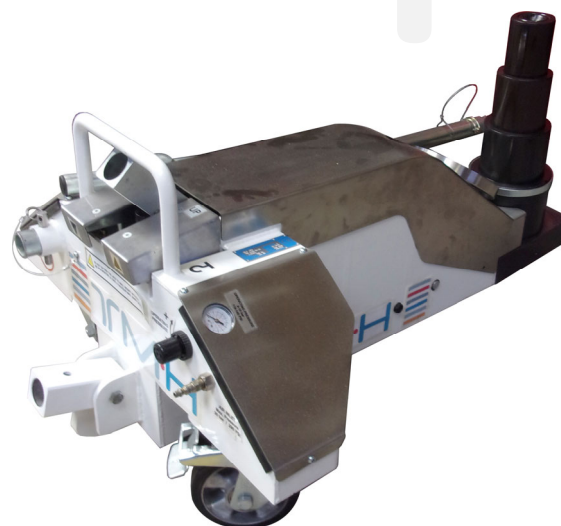

ATA-07

SPECIFICATIONS

Load capacity	49.6 ton US / 45 t (441,45 kN)
Closed height (Ch)	7.5 in / 190 mm
Extended height (Eh)	22.6 in / 573 mm
Hydraulic stroke (Hs)	12.3 in / 313 mm
Screw extension (Se)	2.8 in / 70 mm
Fluid type or equivalent	MIL-H-5606 E mineral oil
Operating temperature	-13° F to +122° F / -25° C à +50° C
Nominal pressure	10300 psi / 710 bar
Tank capacity	2.1 gal US / 8 l
Overall length (Ol)	47.2 in / 1200 mm
Overall width (Ow)	21.3 in / 540 mm
Overall height (Oh)	14.8 in / 375 mm
Weight (without oil)	310.8 lb / 141 kg

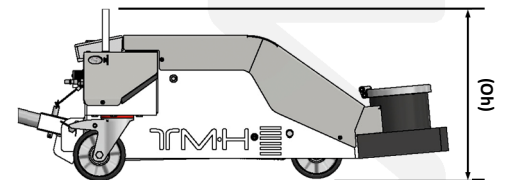
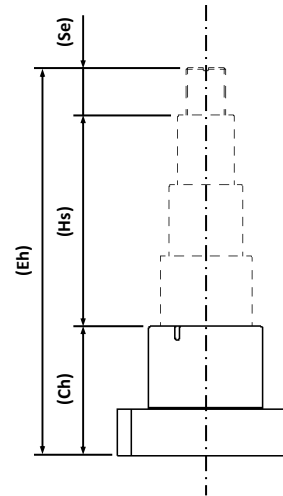

SHIPPING DATA

Dimensions L x w x h	50 x 23.7 x 15.7 in / 130 x 60 x 40 cm
Weight	319.7 lb / 145 kg

TYPICAL AIRCRAFT APPLICATIONS

NLG	<ul style="list-style-type: none"> - A300, A310 (N, 1F) - A320 family CEO (A318, A319, A320, A321) + NEO (N) - A330, A340-200-300 (N, 1F) - B707 (N, 1F) - B727 (N, 1F, 2F) - B737-7-8-9-10 MAX (N) - B737 NG all types (N, 1F), & CL all types (N) - B757 (N) - B767 (N, 1F) - B777 (N, 1F) - B787-8-9 (N, 1F) - E170, E175, E190, E195 (N) - L1011 (N, 1F) - ARJ21 (N, 1F)
MLG	<ul style="list-style-type: none"> - A300, A310 (N, 1F, 2F) - A320 family CEO (A318, A319, A320, A321) + NEO (N, 1F, 2F) - B707 (N, 1F) - B717 (N) - B727 (N, 1F, 2F) - B737-7-8-9-10 MAX (N, 1F, 2F) - B737-7-8-9-10 MAX (with tire size H44.5 x 16.5R21/30PR) (N, 1F, 2F) - B737 NG all types & CL all types (N, 1F, 2F) - B757 (N, 1F) - E170, E175, E190, E195 (N, 1F, 2F) - MD80 (N), MD90 (N) - ARJ21 (N, 1F, 2F)
CLG	N/A

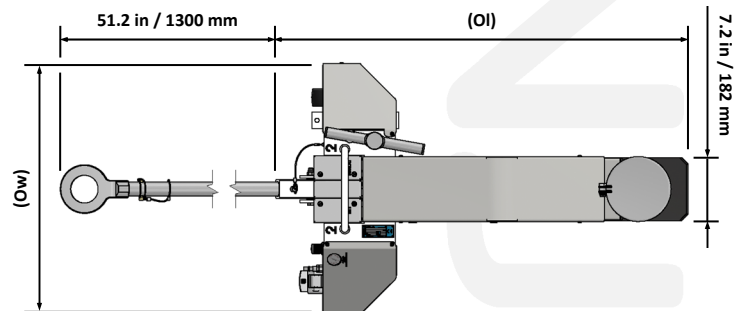

(N) : Two inflated tires - (1F) : One flat tire - (2F) : Two flat tires - (R) : On rim

NLG : Nose Landing Gear
MLG : Main Landing Gear
CLG : Center Landing Gear